

National Crane Series 1100

Product Guide



Features

- 25,4 t (28 USt) rating
- 32,0 m (105 ft) four-section boom
- Self-lubricating Easy Glide wear pads



Features

National Crane 1100

- 25,4 t (28 USt) maximum capacity
 - 49,10 m (161 ft) maximum vertical reach*
 - 34,75 m (114 ft) maximum vertical hydraulic reach
- *Maximum vertical reach is ground-level to boom tip height at maximum extension and angle with outriggers/stabilizers full extended.



Outriggers

The 1100 utilizes "A" frame outriggers with a 23 ft span. Includes RSOD 14 ft out and down, rear stabilizers for standard behind cab mount.



Four-section boom

At 32,0 m (105 ft), the Series 1100 four-section boom is the longest in its size range. The long boom allows the operator to perform more lifts without the use of a jib, reducing setup time and improving efficiency. A 28,96 m (95 ft) four-section boom is also available.

Overload protection

All National Crane boom trucks are equipped with overload protection. A Load Moment Indicator (LMI) is standard on all Series 1100 machines. The LMI display console is weatherproof. The LCD display is visible in full or low light and displays all crane load lifting values simultaneously.



Easy Glide boom wear pads

Easy Glide boom wear pads reduce the conditions that cause boom chatter resulting in smoother crane operation.

Features



Best in class performance and serviceability

- The stronger standard torsion box improves rigidity, reduces truck frame flex and reduces the need for counterweight.
- Crane components painted before assembly reduce the chance of rust, improve serviceability and enhance the appearance of the crane.
- Bearings on the boom and retract cables can be greased through access holes in the boom side plates and number of internal boom parts has been reduced improving serviceability.
- The Series 1100 is supplied with 375° non-continuous rotation standard.
- A state of the art control valve uses specially designed spools to provide optimum control for the smoothest metering and most precise load positioning.

Contents

Mounting configurations	5
Specifications	6
Capacities	8
Dimensions	12
Accessories	13

Mounting configurations

The configurations are based on the Series 1100 with an 85% stability factor. The complete unit must be installed in accordance with factory requirements and a test performed to determine actual stability and counterweight requirements since individual truck chassis vary. Trucks with a frame height in excess of 107 cm (42 in) after mounting will have a final mounted unit height more than 411,5 cm (13.5 ft). Chassis that do not meet these minimum stability weights may require counterweight.

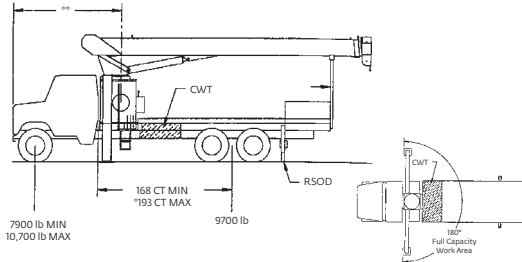

Configuration 1 – 11105

Working area	180°
Gross Axle Weight Rating Front	8165 kg (18,000 lb)
Gross Axle Weight Rating Rear	15 422 kg (34,000 lb)
Gross Vehicle Weight Rating	23 587 kg (52,000 lb)
Wheelbase	650 cm (256 in)
Cab to Axle/trunnion (CA/CT)	488 cm (192 in)
Frame Section Modulus (SM) under crane with 758 MPa (110,000 PSI)	261 cm ³ (15.9 in ³)
Frame Section Modulus (SM) over rear stabilizers with 758 MPa (110,000 PSI)	213 cm ³ (13.0 in ³)
Stability Weight, Front	3583 kg (7900 lb) minimum*
Stability Weight, Rear	4400 kg (9700 lb) minimum*
Estimated Average Final Weight	21 001 kg (46,300 lb)

This configuration allows the installation of the Series 11105 by using the subbase for a 6,71 m (22 ft) bed.

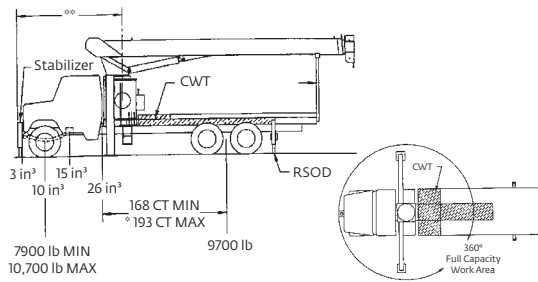

Configuration 2 – 11105 with SFO (Extended front frame rails required for SFO installation.)

Working area	360°
Gross Axle Weight Rating Front	7257 kg (18,000 lb)
Gross Axle Weight Rating Rear	15 422 kg (34,000 lb)
Gross Vehicle Weight Rating	23 587 kg (52,000 lb)
Wheelbase	650 cm (256 in)
Cab to Axle/trunnion (CA/CT)	488 cm (192 in)
Frame Section Modulus (SM) under crane with 758 MPa (110,000 PSI)	426 cm ³ (26.0 in ³)
Frame Section Modulus (SM) over rear stabilizers with 758 MPa (110,000 PSI)	245 cm ³ (15.0 in ³)
Stability Weight, Front	3583 kg (7900 lb) minimum*
Stability Weight, Rear	4400 kg (9700 lb) minimum*
Estimated Average Final Weight	21 001 kg (46,300 lb)

This mount requires front stabilizer for full capacity 360° around the truck. Front stabilizer gives the machine a solid base, helping the operator control loads precisely. This configuration requires a 6,71 m (22 ft) bed.

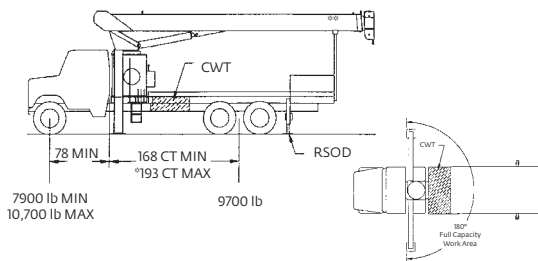

Configuration 3 – 1195

Working area	180°
Gross Axle Weight Rating Front	8165 kg (18,000 lb)
Gross Axle Weight Rating Rear	15 422 kg (34,000 lb)
Gross Vehicle Weight Rating	23 587 kg (52,000 lb)
Wheelbase	625 cm (246 in)
Cab to Axle/trunnion (CA/CT)	427 cm (168 in)
Frame Section Modulus (SM) under crane with 758 MPa (110,000 PSI)	261 cm ³ (15.9 in ³)
Frame Section Modulus (SM) over rear stabilizers with 758 MPa (110,000 PSI)	213 cm ³ (13.0 in ³)
Stability Weight, Front	3583 kg (7900 lb) minimum*
Stability Weight, Rear	4400 kg (9700 lb) minimum*
Estimated Average Final Weight	20 321 kg (44,800 lb)

This configuration allows the installation of the Series 1195 on a chassis with a small frame by using a subbase for a 6,10 m (20 ft) bed or a different subbase for a 6,71 m (22 ft) bed.

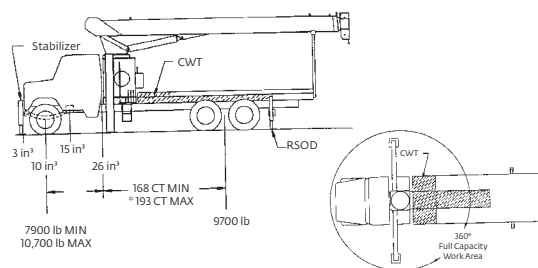

Configuration 4 – 1195 with SFO (Extended front frame rails required for SFO installation.)

Working area	360°
Gross Axle Weight Rating Front	8165 kg (18,000 lb)
Gross Axle Weight Rating Rear	15 422 kg (34,000 lb)
Gross Vehicle Weight Rating	23 587 kg (52,000 lb)
Wheelbase	625 cm (246 in)
Cab to Axle/trunnion (CA/CT)	427 cm (168 in)
Frame Section Modulus (SM) under crane with 758 MPa (110,000 PSI)	426 cm ³ (26.0 in ³)
Frame Section Modulus (SM) over rear stabilizers with 758 MPa (110,000 PSI)	213 cm ³ (13.0 in ³)
Stability Weight, Front	3583 kg (7900 lb) minimum*
Stability Weight, Rear	4400 kg (9700 lb) minimum*
Estimated Average Final Weight	20 321 kg (44,800 lb)

This configuration allows the installation of the 1195 on a chassis by using a subbase for a 6,10 m (20 ft) bed or a different subbase for a 6,71 m (22 ft) bed. This mount requires front stabilizer for full capacity 360° around the truck. Front stabilizer gives the machine a solid base, helping the operator control loads.

Notes:

- Gross Vehicle Weight rating (GVWR) is dependent on all components of the vehicle (axles, tires, springs, frame, etc.) meeting manufacturers' recommendations; always specify GVWR when purchasing trucks
- Diesel engines require a variable speed governor and energize-to-run fuel solenoid for smooth crane operation; electronic fuel injection requires EET engine remote throttle

- All mounting data is based on a National Crane Series 1100 with an 85% stability factor
- The complete unit must be installed in accordance with factory requirements, and a test performed to determine actual stability and counterweight requirements per SAE J765; contact the factory for details
- Transmission neutral safety interlock switch is required with optional remote control

*Estimated axle scale weights prior to installation of crane, stabilizers and subbase for 85% stability.

**If the distance from the front bumper (SFO) to center of rotation exceeds (366 cm 144 in), the (12.19 m 40 ft) overall truck length restriction will be exceeded. Overall length restrictions vary from state to state. In some states it is legal to be more than (12.18 m 40 ft) in length, and some states allow overlength permits.

Specifications

Boom and jib combinations data

Available in two basic models

Model 1195 — Equipped with a 8,53 m - 28,96 m (28 ft - 95 ft) four-section boom. This model can be equipped with a 7,62 m - 13,41 m (25 ft - 44 ft) manual pull-out jib. Maximum tip height with 13,41 m (44 ft) jib is 44,81 m (147 ft).

8,54 m - 28,96 m (28 ft - 95 ft) four-section boom **11FJ44M** 7,62 m - 13,41 m (25 ft - 44 ft) manual pull-out jib



Model 11105 — Equipped with a 9,44 m - 32,01 m (31 ft - 105 ft) four-section boom. This model can be equipped with a 7,62 m - 13,41 m (25 ft - 44 ft) manual pull-out jib. Maximum tip height with 13,41 m (44 ft) jib is 47,85 m (157 ft).

9,45 m - 32,01 m (31 ft - 105 ft) four-section boom **11FJ44M** 7,62 m - 13,41 m (25 ft - 44 ft) manual pull-out jib



Note: Maximum tip is measured with outriggers/stabilizers fully extended.

Specifications

1100 winch data

- All winch pulls and speeds in this chart are shown on the fourth layer
- Winch line pulls would increase on the first, second and third layers
- Winch line pulls may be limited by the winch capacity or the ANSI 5 to 1 cable safety factor
- Hook blocks are rated at maximum capacity for the block. Do not exceed rated cable pull with any block

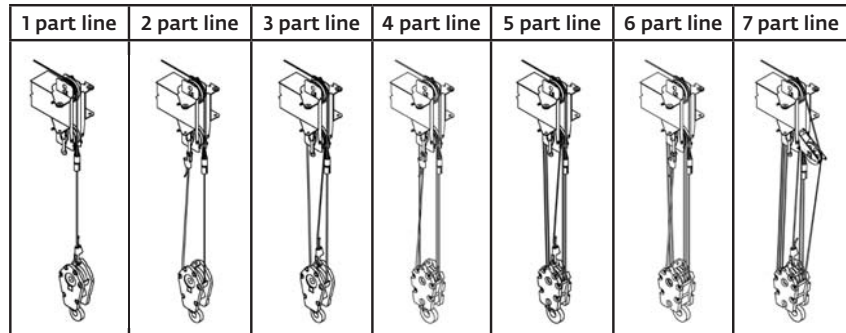

Winch	Cable supplied	Average breaking strength	1 part line Lift and speed	2 part line Lift and speed	3 part line Lift and speed	4 part line Lift and speed	5 part line Lift and speed	6 part line Lift and speed	7 part line Lift and speed
Standard planetary winch	9/16" diameter rotation resistant	17 463 kg (38,500 lb)	3492 kg (7700 lb) 50 m/min (164 fpm)	6985 kg (15,400 lb) 25 m/min (82 fpm)	10 477 kg (23,100 lb) 17 m/min (55 fpm)	13 970 kg (30,800 lb) 13 m/min (41 fpm)	17 463 kg (38,500 lb) 10 m/min (33 fpm)	20 955 kg (46,200 lb) 8 m/min (27 fpm)	24 449 kg (53,900 lb) 7 m/min (23 fpm)
With Burst of Speed winch	Same as corresponding data shown above		1361 kg (3000 lb) 181 m/min (265 fpm)	2722 kg (6000 lb) 41 m/min (133 fpm)	4082 kg (9000 lb) 27 m/min (88 fpm)	5443 kg (12,000 lb) 20 m/min (66 fpm)	6803 kg (15,000 lb) 16 m/min (53 fpm)	8164 kg (18,000 lb) 13 m/min (44 fpm)	9525 kg (21,000 lb) 11 m/min (37 fpm)

Winch	Bare drum pull	Allowable cable pull
With standard rotation resistant rope	4536 kg (10,000 lb)	3493 kg (7700 lb)

Block type	Loadline deduct	
	Rating	Weight
Downhaul weight	3,49 t (3.85 USt)	68 kg (150 lb)
1-sheave block	10,48 t (11.55 USt)	138 kg (305 lb)
2-sheave block	17,46 t (19.25 USt)	161 kg (355 lb)
3-sheave block	25,40 t (28.0 USt)	261 kg (575 lb)

Capacities

Series 1195: 95 ft boom

Other Series 1100 Load Rating Charts are available. National Crane will send you a chart on request – or you may secure needed load rating information through your nearest National Crane dealer.

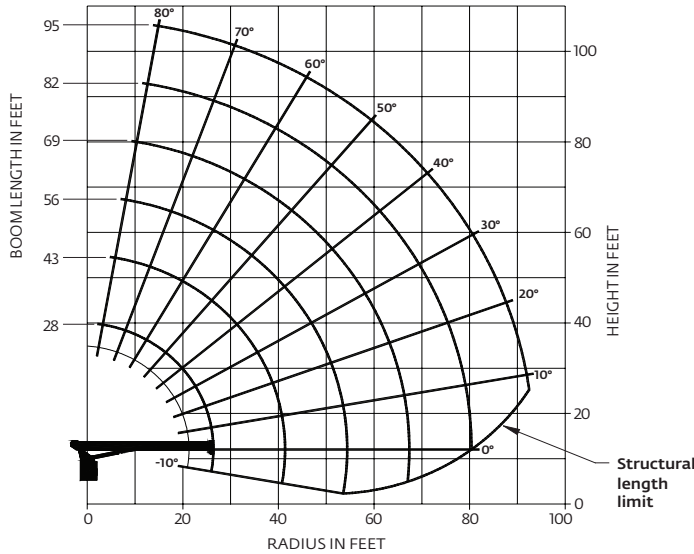

CAUTION:

- Do not operate crane booms, jib extensions, any accessories or loads within 3 m (10 ft) of live power lines or other conductors of electricity.
- Jib and boom capacities shown are maximum for each section.
- Do not exceed capacities at reduced radii.
- Load ratings shown on the load rating charts are maximum allowable loads with the outriggers properly extended on a firm, level surface and the crane leveled and mounted on a factory recommended truck.
- Always level the crane with the level indicator located on the crane.
- The operator must reduce load to allow for factors such as wind, ground conditions, operating speeds and their effects on freely suspended loads.
- Overloading this crane may cause structural collapse or instability.
- Weights on any accessories attached to the boom or loadline must be deducted from the load chart capacities.
- Do not exceed jib capabilities at any reduced boom lengths.
- Do not deadhead lineblock against boom tip when extending boom or winching up.
- Keep at least three wraps of loadline on drum at all times.
- Use only specified cable with this machine.

Load chart

LOAD RADIUS (ft)	LOADED BOOM ANGLE	28 ft BOOM (lb)	LOADED BOOM ANGLE	43 ft BOOM (lb)	LOADED BOOM ANGLE	56 ft BOOM (lb)	LOADED BOOM ANGLE	69 ft BOOM (lb)	LOADED BOOM ANGLE	82 ft BOOM (lb)	LOADED BOOM ANGLE	95 ft BOOM (lb)
5	78.5	*53,900										
8	71.5	40,300										
10	67	33,700	76	30,500								
12	62.5	28,900	73.5	26,200	78	24,000						
14	57.5	25,400	70.5	23,000	76	21,000	79	19,000				
16	52	22,400	67.5	20,400	73.5	18,700	77.5	17,000	80	14,500		
20	40	17,700	61.5	16,700	69	15,300	74	13,900	77	12,500	79	10,200
25	17.5	11,800	53	13,500	63.5	12,400	69.5	11,400	73.5	10,500	76	9000
30			43.5	11,000	57.5	10,400	65	9600	69.5	8900	73	8000
35			32	8800	50.5	8800	60	8200	66	7500	70	7000
40			15.5	6200	44	7500	55	7100	62	6600	66.5	6100
45					35.5	6100	50	5950	58	5650	63	5300
50					24.5	4900	43.5	4950	53.5	4750	59.5	4600
55							37	4100	48.5	4000	56	4000
60							28.5	3350	43.5	3400	52	3400
65							16.5	2600	37.5	2800	47.5	2850
70									31	2300	43	2350
75									22.5	1900	38	1950
80											32.5	1550
85											26	1250
90											16.5	950
	0	6200	0	2900	0	1450	0	650				

*Note: 56,000 lb (28 USt) load requires optional 9/16 in 6x25 IWRC cable. Shaded areas are structurally limited capacities.

THIS CHART IS ONLY A GUIDE AND SHOULD NOT BE USED TO OPERATE THE CRANE.

The individual crane's load chart, operating instructions and other instructional plates must be read and understood prior to operating the crane.

Capacities

Series 1195: 95 ft boom with 44 ft jib

Other Series 1100 Load Rating Charts are available. National Crane will send you a chart on request – or you may secure needed load rating information through your nearest National Crane dealer.

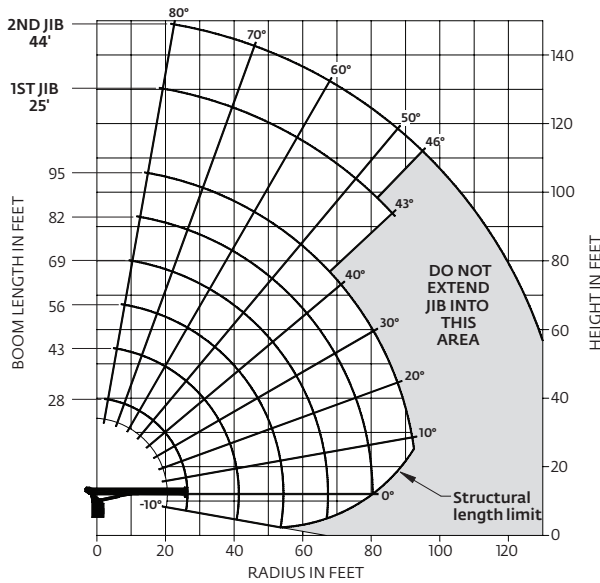

CAUTION:

- Do not operate crane booms, jib extensions, any accessories or loads within 3 m (10 ft) of live power lines or other conductors of electricity.
- Jib and boom capacities shown are maximum for each section.
- Do not exceed capacities at reduced radii.
- Load ratings shown on the load rating charts are maximum allowable loads with the outriggers properly extended on a firm, level surface and the crane leveled and mounted on a factory recommended truck.
- Always level the crane with the level indicator located on the crane.
- The operator must reduce load to allow for factors such as wind, ground conditions, operating speeds and their effects on freely suspended loads.
- Overloading this crane may cause structural collapse or instability.
- Weights on any accessories attached to the boom or loadline must be deducted from the load chart capacities.
- Do not exceed jib capabilities at any reduced boom lengths.
- Do not deadhead lineblock against boom tip when extending boom or winching up.
- Keep at least three wraps of loadline on drum at all times.
- Use only specified cable with this machine.

NOTE:

1. Operate with jib by radius when main boom is fully extended. If necessary increase boom angle to maintain loaded radius.
2. Operate with jib by boom angle when main boom is not fully extended. Do not exceed rated jib capacities at any reduced boom lengths.

Load chart

LOAD RADIUS (ft)	LOADED BOOM ANGLE	28 ft BOOM (lb)	LOADED BOOM ANGLE	43 ft BOOM (lb)	LOADED BOOM ANGLE	56 ft BOOM (lb)	LOADED BOOM ANGLE	69 ft BOOM (lb)	LOADED BOOM ANGLE	82 ft BOOM (lb)	LOADED BOOM ANGLE	95 ft BOOM (lb)
5	78.5	53,900										
8	71.5	39,700										
10	67	33,100	76	30,100								
12	62.5	28,300	73.5	25,800	78	23,700						
14	57.5	24,800	70.5	22,600	76	20,700	79	18,700				
16	52	21,800	67.5	20,000	73.5	18,400	77.5	16,700	80	14,300		
20	40	17,100	61.5	16,300	69	15,000	74	13,600	77	12,300	79	10,000
25	17.5	11,200	53	13,100	63.5	12,100	69.5	11,100	73.5	10,300	76	8,800
30			43.5	10,600	57.5	10,100	65	9,300	69.5	8,700	73	7,800
35			32	8,400	50.5	8,500	60	7,900	66	7,300	70	6,800
40			15.5	5,800	44	7,200	55	6,800	62	6,400	66.5	5,900
45					35.5	5,800	50	5,650	58	5,450	63	5,100
50					24.5	4,600	43.5	4,650	53.5	4,550	59.5	4,400
55							37	3,800	48.5	3,800	56	3,800
60							28.5	3,050	43.5	3,200	52	3,200
65							16.5	2,300	37.5	2,600	47.5	2,650
70									31	2,100	43	2,150
75									22.5	1,700	38	1,750
80											32.5	1,350
85											26	1,050
90											16.5	750
0		5600	0	2500	0	1150	0	350				
ADDD TO CAPACITIES WHEN NO JIB STOWED (lb)		600		400		300		300		200		200

LOAD RADIUS (ft)	LOADED BOOM ANGLE	25 ft JIB (lb)	LOADED BOOM ANGLE	44 ft JIB (lb)
30	77	5200	79.5	3200
35	75	4800	78	3050
40	72.5	4350	76	2850
45	70	3900	74	2650
50	67.5	3500	72	2450
55	65	3050	70	2300
60	62	2550	67	2150
65	59	2100	65	2000
70	56	1750	63	1850
75	52.5	1400	60.5	1600
80	49.5	1100	58	1350
85	46	800	54.5	1150
90	43	600	52	950
95			49	750
100			46	600

*Note: 56,000 lb (28 USt) load requires optional 9/16 in 6x25 IWRC cable. Shaded areas are structurally limited capacities.

Capacities

Series 11105: 105 ft boom

Other Series 1100 Load Rating Charts are available. National Crane will send you a chart on request – or you may secure needed load rating information through your nearest National Crane dealer.

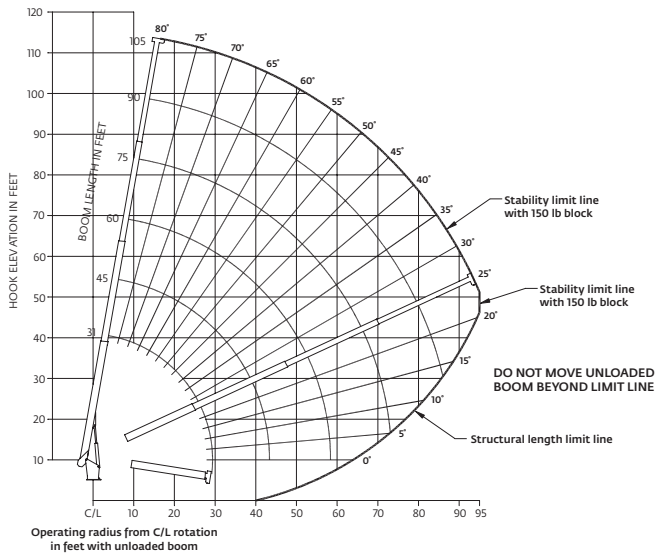

CAUTION:

- Do not operate crane booms, jib extensions, any accessories or loads within 3 m (10 ft) of live power lines or other conductors of electricity.
- Jib and boom capacities shown are maximum for each section.
- Do not exceed capacities at reduced radii.
- Load ratings shown on the load rating charts are maximum allowable loads with the outriggers properly extended on a firm, level surface and the crane leveled and mounted on a factory recommended truck.
- Always level the crane with the level indicator located on the crane.
- The operator must reduce load to allow for factors such as wind, ground conditions, operating speeds and their effects on freely suspended loads.
- Overloading this crane may cause structural collapse or instability.
- Weights on any accessories attached to the boom or loadline must be deducted from the load chart capacities.
- Do not exceed jib capabilities at any reduced boom lengths.
- Do not deadhead lineblock against boom tip when extending boom or winching up.
- Keep at least three wraps of loadline on drum at all times.
- Use only specified cable with this machine.

Load chart

LOAD RADIUS (ft)	LOADED BOOM ANGLE	31 ft BOOM (lb)	LOADED BOOM ANGLE	45 ft BOOM (lb)	LOADED BOOM ANGLE	60 ft BOOM (lb)	LOADED BOOM ANGLE	75 ft BOOM (lb)	LOADED BOOM ANGLE	90 ft BOOM (lb)	LOADED BOOM ANGLE	105 ft BOOM (lb)
5	79.4	*53,900										
8	73.1	38,400	79.3	30,000								
10	68.9	31,800	76.8	29,100								
12	64.6	27,300	74	24,800	78.8	22,300						
14	60.2	23,700	71.2	21,700	76.8	19,500	80	15,400				
16	55.6	21,000	68.4	19,200	74.8	17,300	78.5	15,000				
20	45.5	16,700	62.6	15,600	70.7	14,100	75.4	12,600	78.4	10,800	80.2	7700
25	29.1	12,200	54.8	12,500	65.4	11,300	71.3	10,200	75.1	9000	77.8	7300
30			46.3	10,200	59.8	9400	67.1	8500	71.8	7800	75	6500
35			36.1	8200	53.9	7950	63.1	7050	68.6	6500	72.2	5700
40			23.5	6100	48	6600	58.6	6100	65	5550	69.3	5000
45					40.8	5550	53.8	5250	61.3	4800	66.2	4300
50					32.2	4550	48.7	4550	57.5	4200	63.1	3800
55					20.6	3300	43	3900	53.5	3700	60	3400
60							36.7	3250	49.2	3200	56.6	2950
65							29.1	2650	44.6	2750	53.2	2650
70							18.7	1800	39.4	2200	49.5	2300
75									33.6	1800	45.5	1850
80									26.8	1400	41.2	1450
85									17.2	800	36.5	1150
90											31.2	850
95											24.8	600
	0	5200	0	2400	0	900						

*Note: 56,000 lb (28 USt) load requires optional 9/16 in 6x25 IWRC cable.
Shaded areas are structurally limited capacities.

Capacities

Series 1105: 105 ft boom and 44 ft jib

Other Series 1100 Load Rating Charts are available. National Crane will send you a chart on request – or you may secure needed load rating information through your nearest National Crane dealer.

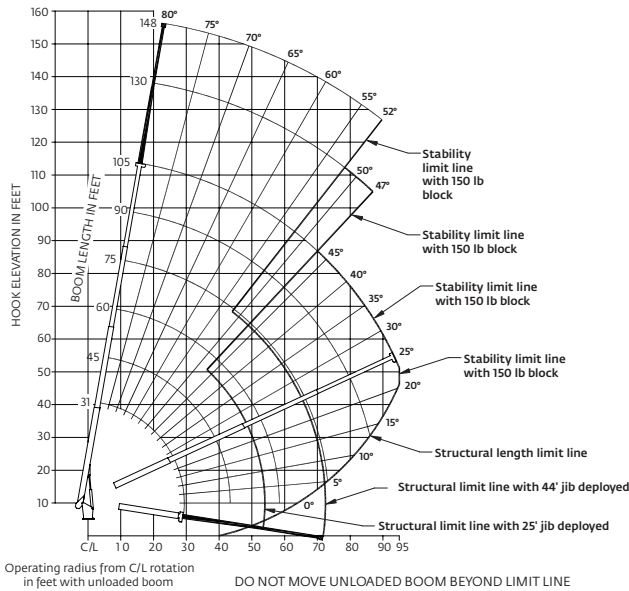

CAUTION:

- Do not operate crane booms, jib extensions, any accessories or loads within 3 m (10 ft) of live power lines or other conductors of electricity.
- Jib and boom capacities shown are maximum for each section.
- Do not exceed capacities at reduced radii.
- Load ratings shown on the load rating charts are maximum allowable loads with the outriggers properly extended on a firm, level surface and the crane leveled and mounted on a factory recommended truck.
- Always level the crane with the level indicator located on the crane.
- The operator must reduce load to allow for factors such as wind, ground conditions, operating speeds and their effects on freely suspended loads.
- Overloading this crane may cause structural collapse or instability.
- Weights on any accessories attached to the boom or loadline must be deducted from the load chart capacities.
- Do not exceed jib capabilities at any reduced boom lengths.
- Do not deadhead lineblock against boom tip when extending boom or winching up.
- Keep at least three wraps of loadline on drum at all times.
- Use only specified cable with this machine.

NOTE:

- Operate with jib by radius when main boom is fully extended. If necessary increase boom angle to maintain loaded radius.
- Operate with jib by boom angle when main boom is not fully extended. Do not exceed rated jib capacities at any reduced boom lengths.

Load chart

LOAD RADIUS (ft)	LOADED BOOM ANGLE	31 ft BOOM (lb)	LOADED BOOM ANGLE	45 ft BOOM (lb)	LOADED BOOM ANGLE	60 ft BOOM (lb)	LOADED BOOM ANGLE	75 ft BOOM (lb)	LOADED BOOM ANGLE	90 ft BOOM (lb)	LOADED BOOM ANGLE	105 ft BOOM (lb)	LOAD RADIUS (ft)	LOADED BOOM ANGLE	25 ft JIB (lb)	LOADED BOOM ANGLE	44 ft JIB (lb)
5	79.4	53,900											30	78.3	4200		
8	73.1	37,550	79.3	29,400									35	76.2	3800	78.2	2400
10	68.9	30,950	76.8	28,500									40	74	3400	76.4	2250
12	64.6	26,450	74	24,200	78.8	21,850							45	71.7	2900	74.7	2150
14	60.2	22,850	71.2	21,100	76.8	19,050	80	15,050					50	69.4	2500	72.8	2000
16	55.6	20,150	68.4	18,600	74.8	16,850	78.5	14,650					55	66.9	2100	70.8	1800
20	45.5	15,850	62.6	15,000	70.7	13,650	75.4	12,250	78.4	10,500	80.2	7450	60	64.5	1800	68.9	1650
25	29.1	11,350	54.8	11,900	65.4	10,850	71.3	9850	75.1	8700	77.8	7050	65	61.9	1500	66.8	1450
30			46.3	9600	59.8	8950	67.1	8150	71.8	7500	75	6250	70	59.4	1300	64.6	1300
35			36.1	7600	53.9	7500	63.1	6700	68.6	6200	72.2	5450	75	56.7	1100	62.4	1100
40			23.5	5500	48	6150	58.6	5750	65	5250	69.3	4750	80	53.9	900	60	900
45					40.8	5100	53.8	4900	61.3	4500	66.2	4050	85	51	700	57.8	800
50					32.2	4100	48.7	4200	57.5	3900	63.1	3550	90	47.9	500	55.4	700
55					20.6	2850	43	3550	53.5	3,400	60	3150	95			52.9	550
60							36.7	2900	49.2	2900	56.6	2700					
65							29.1	2300	44.6	2450	53.2	2400					
70							18.7	1450	39.4	1900	49.5	2050					
75									33.6	1500	45.5	1600					
80									26.8	1100	41.2	1200					
85									17.2	500	36.5	900					
90											31.2	600					
95											24.8	350					
	0	4350	0	1800	0	450											
	ADD TO CAPACITIES WHEN NO JIB STOWED (lb)		850	600	450	350	300	250									

*Note: 56,000 lb (28 USst) load requires optional 9/16 in 6x25 IWRC cable. Shaded areas are structurally limited capacities.

Dimensions

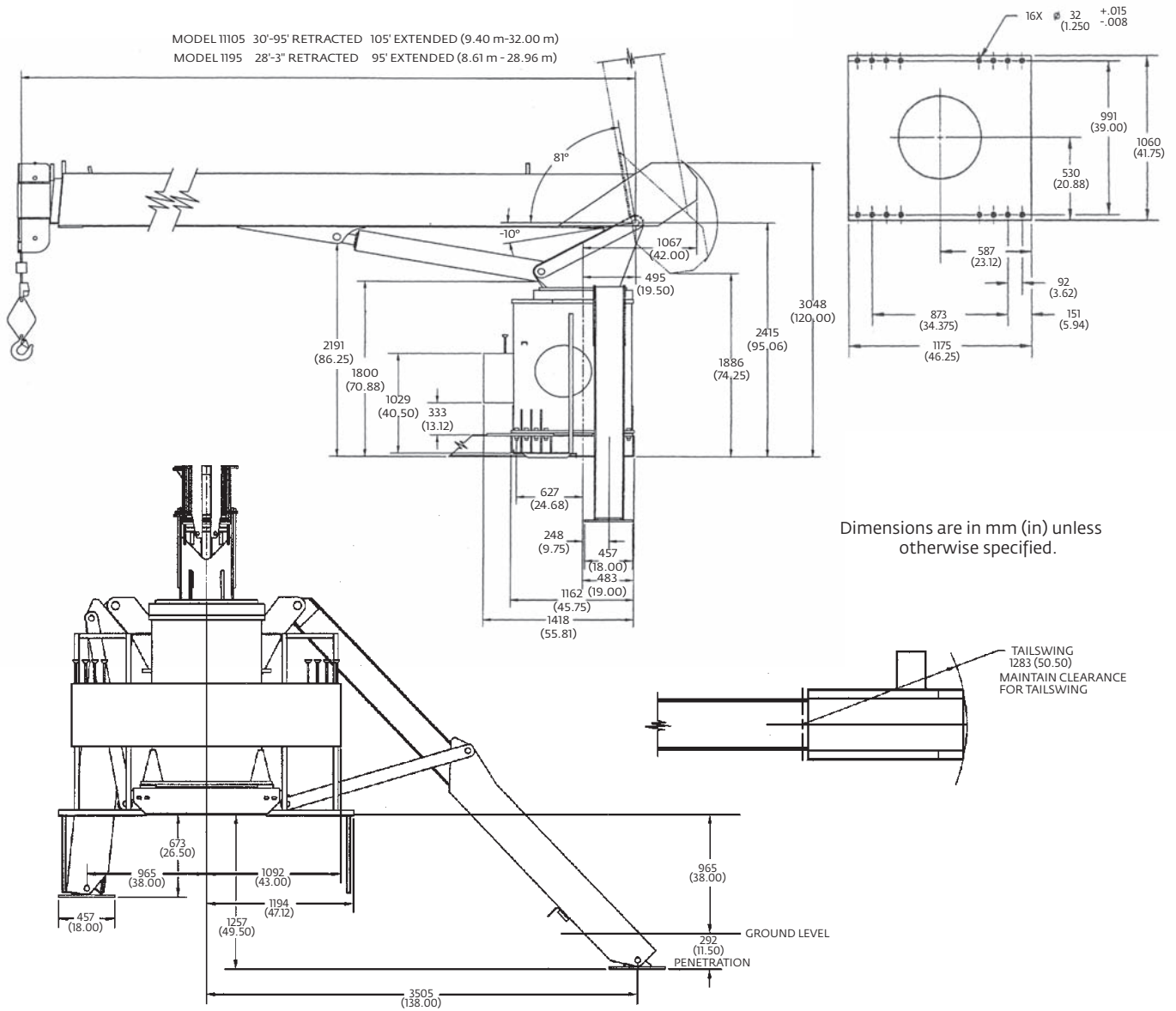

Mount	Series	G mm (in)	Dry weight kg (lb)	With oil weight kg (lb)
Standard	1195	98 (2489)	9434 (20,800)	9798(21,600)
Standard	11105	100 (2540)	9816 (21,640)	10 197 (22,480)

*Weight includes all items except RSOD (1400 lb). Boom fully retracted

Accessories

Radio Remote Controls –

Eliminate the handling and maintenance concerns that accompany cabled remotes. Operate to a range of about 76 m (250 ft), varying with conditions.

- NB4R

Heavy-duty Personnel Basket –

544 kg (1200 lb) capacity steel basket with safety loops for two passengers. Gravity leveling 183 cm x 107 cm (72 in x 42 in) platform. Fast attachment and secure locking systems. Load chart must show 1043 kg (2300 lb) minimum to operate this accessory.

- BSA-1
- BSA-R1 (provides rotation)

Hydraulic Oil Cooler –

Automatic, self-contained radiator system with electric fans cools oil under continuous operation.

- OC

Bulkhead Option –

Steel 30 in solid wall bulkhead for all flatbeds.

- BHSD

Spanish-Language Danger Decals, Control Knobs, and Operators' Manuals

- SDD
- SOM



For Rental Inquiries Please Call (800) 335-3148 Or Visit Us On The Web At Southwaycrane.com

Notes



For Rental Inquiries Please Call (800) 335-3148 Or Visit Us On The Web At Southwaycrane.com

Notes

Regional headquarters

Manitowoc - Americas

Manitowoc, Wisconsin, USA

Tel: +1 920 684 6621

Fax: +1 920 683 6277

Shady Grove, Pennsylvania, USA

Tel: +1 717 597 8121

Fax: +1 717 597 4062

Manitowoc - Europe, Middle East, Africa

Ecully, France

Tel: +33 (0)4 72 18 20 20

Fax: +33 (0)4 72 18 20 00

Manitowoc - Asia Pacific

Shanghai, China

Tel: +86 21 6457 0066

Fax: +86 21 6457 4955

Regional offices

Americas

Brazil

Alphaville

Mexico

Monterrey

Chile

Santiago

Europe, Middle East, Africa

Czech Republic

Netvorice

France

Baudemont

Cergy

Decines

Germany

Langenfeld

Hungary

Budapest

Italy

Parabiago

Netherlands

Breda

Poland

Warsaw

Portugal

Baltar

Russia

Moscow

U.A.E.

Dubai

U.K.

Buckingham

Asia - Pacific

Australia

Brisbane

Melbourne

Sydney

China

Beijing

Chengdu

Guangzhou

India

Delhi

Hyderabad

Pune

Korea

Seoul

Philippines

Makati City

Singapore

Factories

Brazil

Alphaville

China

TaiAn

Zhangjiagang

France

Charlieu

La Clayette

Moulins

Germany

Wilhelmshaven

India

Pune

Italy

Niella Tanaro

Portugal

Baltar

Fânzeres

Slovakia

Saris

USA

Manitowoc

Port Washington

Shady Grove

This document is non-contractual. Constant improvement and engineering progress make it necessary that we reserve the right to make specification, equipment, and price changes without notice. Illustrations shown may include optional equipment and accessories and may not include all standard equipment.